

**KLH<sup>®</sup>**

**MADE FOR BUILDING**  
BUILT FOR LIVING

**BUILDING PHYSICS**

## IMPRINT

© KLH Massivholz GmbH

Publisher and responsible for content: KLH Massivholz GmbH  
Version: 01/2012, Building physics

The content of this brochure is the intellectual property of the company and is protected by copyright. The statements are recommendations and suggestions only; liability on the part of the publisher is excluded.  
Any type of reproduction is strictly forbidden and only permitted after written approval from the publisher.

---



---

CONTENT

---

01	AIR TIGHTNESS .....	03
02	HEAT INSULATION .....	06
03	DURABILITY .....	12
04	PROTECTION AGAINST MOISTURE .....	14
05	SOUND INSULATION .....	18
06	FIRE PROTECTION .....	23
07	BIBLIOGRAPHY .....	25

# BUILDING PHYSICS

Measures to counteract or slow down global warming are constantly being searched for. In this respect it is essential to create Energy Performance Certificates to assess buildings energetically and to contribute to climate protection on a legal basis.

In Austria, the issue, use, principles and basics of energy performance certificates are defined by various provincial laws and the Energy Performance Certificate Presentation Act (EAVG). These legal norms are intended to transpose the Energy Performance of Buildings Directive (EPBD), Directive 2002/91/EC, on the total energy efficiency in buildings into national law. Standard ÖNORM H 5055 regulates the energy performance certificate for buildings.

In principle this means keeping the required heating warmth in the building in winter and preventing heat from penetrating the building envelope in summer, particularly as the use of air-conditioning systems mostly involves high energy expenditure.

The energy performance certificate indicates to what extent a building fulfils or does not fulfil the climate protection requirements. By means of thermal imaging cameras it is furthermore possible to make thermographic building surveys, as well as to visualise energy losses and make them measurable.

Through the application of KLH solid wood panels it is possible to make use of essential advantages, such as the air tightness of the structure, avoidance of thermal bridges by means of homogeneous layers, high energy storage mass for warmth protection in summer and higher application tolerance through existing moisture storage mass. The increased use of KLH solid wood panels in passive house technology shows that solid timber construction generally constitutes a sensible approach towards sustainability and reduced CO<sub>2</sub> emissions.

## 01 AIR TIGHTNESS

### 1.1 GENERAL INFORMATION

Air tightness – or more accurately referred to as convection tightness – is an essential parameter of modern and sustainable constructions.

“The heat-transmitting enfolded area including the joints must be permanently made airtight according to the acknowledged rules of technology.” [7.1]

According to OIB – Directive 6 “Energy savings and heat insulation”, the building envelope of new constructions must be made permanently airtight and windproof. The air change rate n50, measured at a pressure difference of 50 Pascal between interior and exterior space and

determined through negative and positive pressure, with closed openings of outgoing and incoming air, must not exceed a value of 3.0 per hour. If a mechanically operated ventilation system is installed – with or without heat recovery – the air change rate n50 must not exceed the value of 1.5 per hour. For detached houses, semi-detached houses and terraced houses, this value is required for each house, and for multi-family houses it must be reached per living unit. Passive houses require an air change rate of  $n50 < 0.6 \text{ h}^{-1}$ . [7.2]

### 1.2 “WINDPROOF” DOES NOT MEAN “AIRTIGHT”

In practice, very often no difference is made between these two terms, although there are clear distinctions to be made. Wind tightness of a construction component prevents air flows from entering insulation layers and thus the loss of heat into the open. The wind-proofness of buildings can be compared to the outside material of winter jackets: if the windproof layer is missing, heat will escape and cause a person to feel cold. As wind insulations are always located at the outside of the insulation layers, the vapour diffusion resistance of the wind insulation should be as low as possible, and it should be taken into account in physical construction considerations.

The air tightness of a construction component or an entire building is a measurable unit (air change rate).

It indicates the amount of air per hour [ $\text{m}^3/\text{h}$ ] flowing between the inside and outside of a construction component and/or building at a certain defined pressure difference. The resulting n50 value, calculated from positive and negative pressure volume flows at 50 Pascal, classifies a construction component with respect to its overall

tightness. Nevertheless, a good n50 value alone is still no guarantee for fault-free constructional design. Only an exact investigation of the building by an expert (e.g. by means of a Blower Door Test) will show whether work was carried out down to the last details, and whether any later constructional damage can be excluded or not.

“A building is not supposed to be completely airtight. It must still be able to breathe.” This is a statement often heard in discussions on the topic of building tightness.

We should add the following explanatory quote: “The ventilation of inhabited rooms through building joints can never be sufficient. Even very permeable buildings with a considerable draft during moderate winds have insufficient air exchange during windless, mild weather periods. Therefore, the air flow through joints has a number of disadvantages: for example, a high percentage of all construction damage is caused by overly permeable building envelopes. Other disadvantages of joints are the lack of noise protection and excessive heat loss.” [7.3]

## AIR TIGHTNESS

### 1.3 AIR TIGHTNESS OF THE KLH SOLID WOOD PANEL

Measurements with KLH solid wood panels have shown that 3-layer KLH solid wood panels with one-sided industrial visual quality or domestic visual quality are sufficiently airtight and can therefore be used as an airtight layer. Panels with 5 or more layers also fulfil this criterion in non-visual quality.

In principle, there are two options for the airtight design of a KLH construction: either the tightness of the construction is provided by installing a flow-tight layer (e.g.

a vapour retarder adjusted to the further wall structure, also serving as a convection barrier, compare fig. 1; the entire building is wrapped and sealed with a membrane, usually a textile fabric) or the KLH construction as such is used as the building's tightness layer. In this case the construction component's edges as well as all joints between the construction components or to adjacent construction components are sealed with e.g. pre-compressed sealing tapes (compare fig. 2).

Flow-tight exterior walls with film applied outside (vapour tightness of film adjusted to further wall structure)

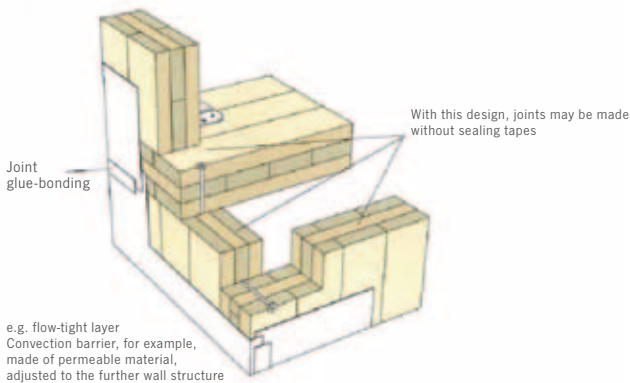

Fig. 1 – Flow-tight connection through wrapping and sealing by way of a convection barrier

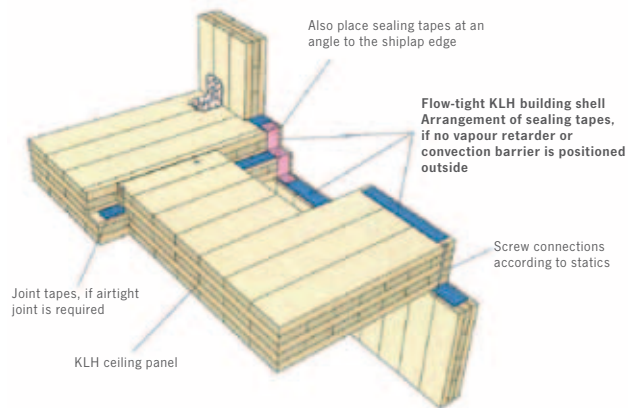

Fig. 2 – Flow-tight connection of KLH solid wood panels by way of sealing tapes

AIR TIGHTNESS

The tightness of the KLH construction much less depends on the panel, but more on the connection joints to other construction components and panel joints.

Construction component connections, joint connections, penetrations, etc. must be sealed according to the acknowledged rules of technology. We recommend testing the tightness of the construction by Blower Door measurement – if possible even before completion of the

construction (possibly with the use of 3-layer KLH solid wood panels in non-visual quality). If leaks are found during such measurements, it is normally possible to eliminate them without any extensive efforts. Basically, the Blower Door Test is only required for certified passive houses. All low-energy houses with KLH elements can be built confidently without any testing, if the joint connections are made correctly.

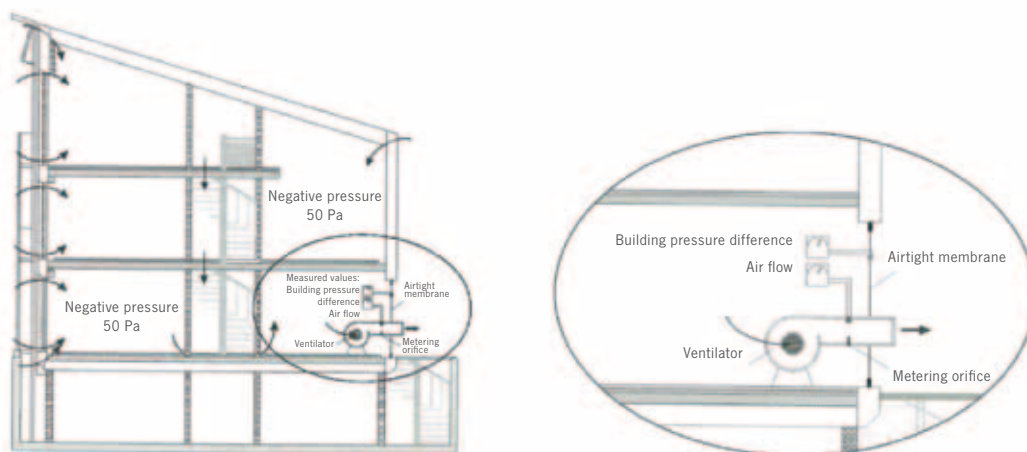

Fig. 3 – Schematic depiction of a Blower Door Measurement [7.3]

With conclusive planning and the correct installation of the air tightness layer with joint tapes, even three-dimensional connection points can be tackled (compare fig. 2, shiplap edge in ceiling area). What is important in this

regard is the arrangement of the sealing tape in the centre of the panel. This will achieve maximum tightness in both directions.

## 02 HEAT INSULATION

### 2.1 GENERAL INFORMATION

2 key figures determine heat insulation: [7.4]

- Heat conductivity
- Convection tightness

The use of KLH solid wood panels for wall and ceiling structures is of an advantage, because it can be installed in mostly homogenous layers, as opposed to other light-weight construction types. This leads to even temperature fields across the entire surface and is also advantageous for the hygro-thermal behaviour of the construction (safety potential due to the available moisture storage mass of the existing solid wood wall, higher application tolerance) – the construction becomes more resilient.

Heat conductivity essentially depends on the gross density and moisture content of the KLH solid wood panel. For “timber” with a gross density of 500 kg/m<sup>3</sup>, ÖNORM 12524 [7.5] only provides a rated heat conductivity of 0.13 W/(m\*K). For spruce wood, ÖNORM B 3012 [7.6] provides a  $\lambda$ -value of 0.11 W/(m\*K) at relative wood moisture of 12%.

Laboratory tests by the French institute CSTB (Centre Scientifique et Technique du Bâtiment) with 3 and 5-layer KLH samples resulted in a  $\lambda$ -value of 0.10 W/(m\*K).

In case of a solid KLH exterior wall humidity of less than 12% can be expected during the relevant winter months. Due to this reason, a  $\lambda$ -value of 0.11 W/(m\*K) is applied for KLH construction components in the examples below.

It has to be pointed out that the thermal behaviour of the KLH solid wood panel can only be realistically assessed with unsteady humidity and heat flow calculations. For example, unsteady mathematical models form the basis of the programmes “Delfin” or “Wufi”.

The high gross density of wood causes a long phase shift (= time between the occurrence of the highest temperature on the outside surface of a construction component until the time the highest temperature is reached on its inside surface). This is particularly important for heat insulation in summer, since long phase shifts mean that buildings remain cool inside, even with high outside temperatures. During low outside temperatures, this principle has the exact inverse effect.

The U-value used to calculate the heating energy demand only gives information about how much heat is permanently lost. It does not tell how long it takes until this loss actually takes place. The heating energy demand of buildings made of KLH solid wood panels is low. On the one hand, this is due to the high gross density of the elements and the high specific heat capacity. On the other hand, it is due to the low temperature penetration coefficient and the low heat conductivity.



HEAT INSULATION

2.2 HEAT INSULATION IN WINTER

The aim inside buildings during winter is to create temperatures that ensure a high level of comfort.

There are three different options

- Reducing transmission loss (heat transfer through construction components, heat is transferred outside and is lost)
- Adding thermal energy from outside (solar energy through windows)
- Adding internal thermal energy (heating energy, energy consumption in the household)

The determining factor is heat conductivity, better known as the U-value.

The U-value consists of the properties of the construction component and the position in the building (the heat transmission resistance values  $R_{si}$  and  $R_{se}$  may vary). The smaller the U-value, the higher the construction component's resistance against letting heat escape to the outside.

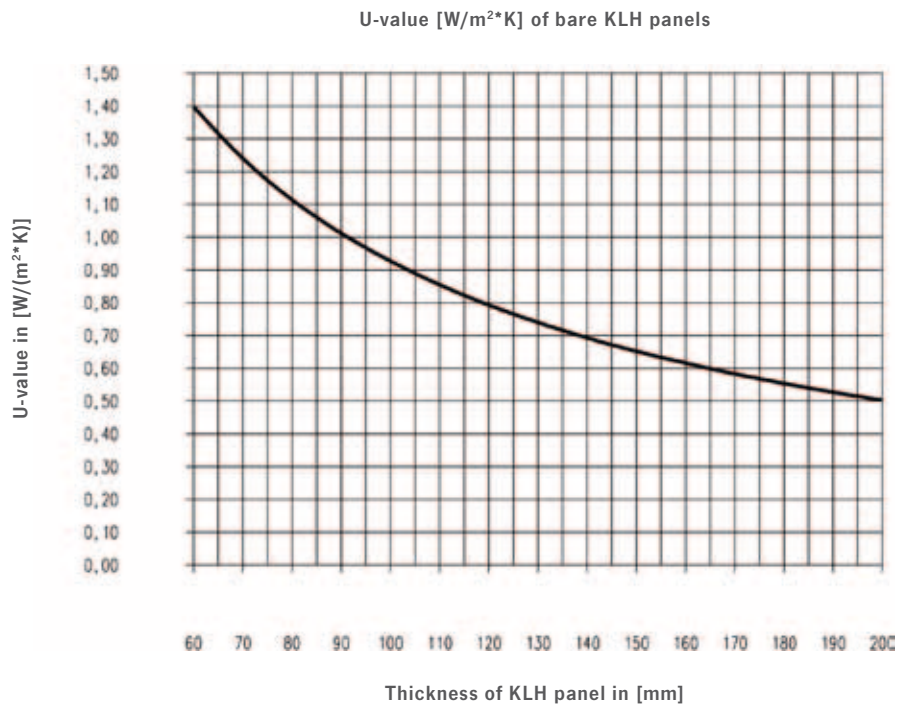

Fig. 4 – Heat transfer coefficient depending on panel thickness (with  $\lambda_{KLH} = 0.11$  W/(m\*K))

## HEAT INSULATION

### Example of the U-value of an insulated KLH element

In combination with a 140 mm thick insulation of thermal conductivity group 035 (TCG 035), the U-value of a 94 mm thick KLH wall element is calculated as follows:

Heat transfer coefficient  $U = \frac{1}{R_{si} + \sum \frac{d_i}{\lambda_i} + R_{se}}$

Heat transmission resistance  $R_{si} = 0.13 \text{ m}^2 \cdot \text{K}/\text{W}$

$R_{se} = 0.04 \text{ m}^2 \cdot \text{K}/\text{W}$

KLH thermal conductivity  $\lambda_{KLH} = 0.11 \text{ W}/(\text{m} \cdot \text{K})$

Heat transfer coefficient  $U = \frac{1}{0.13 + \frac{0.094}{0.11} + \frac{0.14}{0.035} + 0.04} = 0.199 \text{ W}/(\text{m}^2 \cdot \text{K})$

The figure below shows a diagram where the U-values of insulated KLH wall elements with a thickness of 94 mm are listed in reference to the thickness of the insulation material (TCG 035).

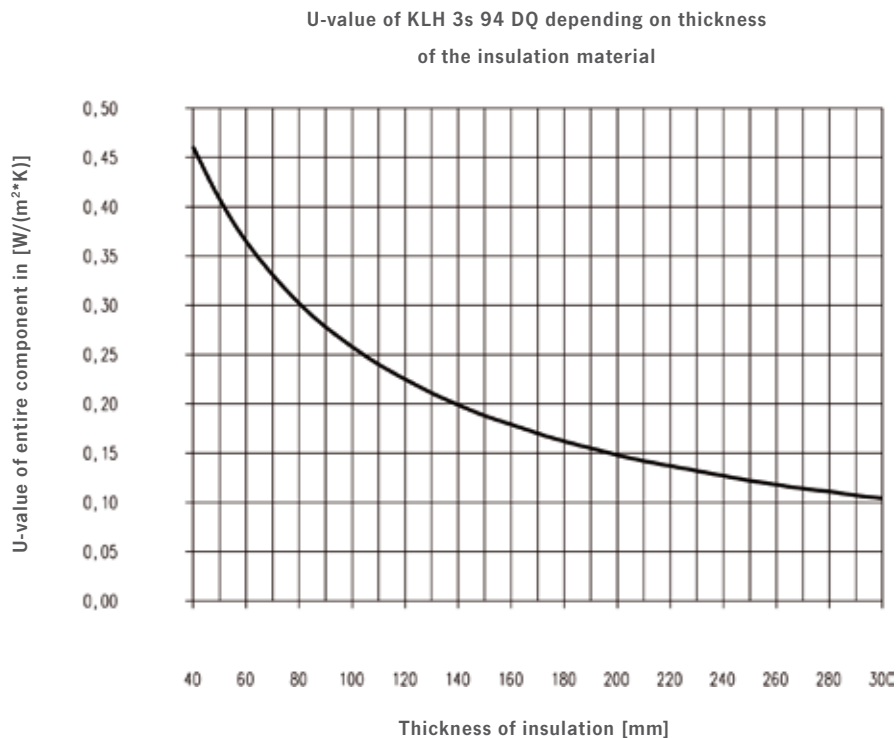
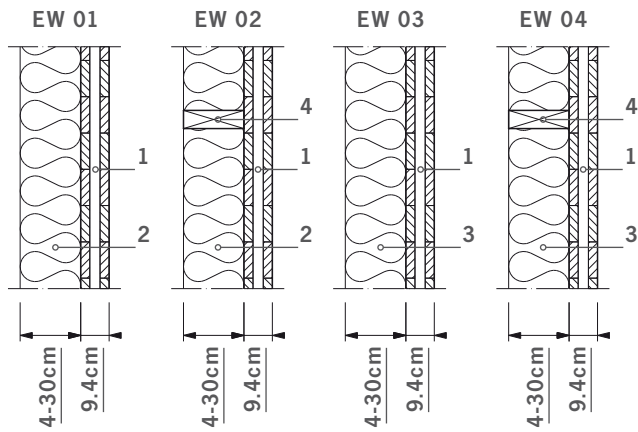

Fig. 5 - U-value of wall structures (KLH 3s 94 DQ) with variable insulation material thicknesses

## HEAT INSULATION

### U-value – comparative examples



#### Key to fig. 6

- 1 KLH 3s 94 DQ ( $\lambda_{\text{KLH}} = 0.11 \text{ W}/(\text{m} \cdot \text{K})$ )
- 2 Insulation TCG 040 ( $\lambda = 0.040 \text{ W}/(\text{m} \cdot \text{K})$ )
- 3 Insulation TCG 035 ( $\lambda = 0.035 \text{ W}/(\text{m} \cdot \text{K})$ )
- 4 Battens, etc. in insulation layer,  $\lambda = 0.13 \text{ W}/(\text{m} \cdot \text{K})$   
(percentage of wood 10%, insulation 90%)

Fig. 6 – Insulated KLH exterior wall (KLH 3s 94 DQ) in four different variants

Assumed heat transmission coefficients:

$$R_{\text{si}} = 0.13 \text{ m}^2 \cdot \text{K}/\text{W}$$

$$R_{\text{se}} = 0.04 \text{ m}^2 \cdot \text{K}/\text{W}$$

### HEAT TRANSFER COEFFICIENT

		EW 01	EW 02	EW 03	EW 04
		TCG 040	TCG 040	TCG 035	TCG 035
		Insulation 100%	Insulation 90%	Insulation 100%	Insulation 90%
		Percentage of wood 0%	Percentage of wood 10%	Percentage of wood 0%	Percentage of wood 10%
Insulation thickness [mm]	Overall thickness [cm]	U-value [W/(m <sup>2</sup> ·K)]	U <sub>m</sub> -value [W/(m <sup>2</sup> ·K)]	U-value [W/(m <sup>2</sup> ·K)]	U <sub>m</sub> -value [W/(m <sup>2</sup> ·K)]
40	13.4	0.494	0.531	0.461	0.505
60	15.4	0.396	0.434	0.356	0.408
80	17.4	0.331	0.367	0.302	0.343
100	19.4	0.284	0.318	0.258	0.296
120	21.4	0.248	0.281	0.225	0.261
140	23.4	0.221	0.252	0.199	0.233
160	25.4	0.199	0.228	0.179	0.211
180	27.4	0.181	0.209	0.162	0.192
200	29.4	0.166	0.192	0.148	0.177

Table 2: Numerical analysis of examples in reference to fig. 6

HEAT INSULATION

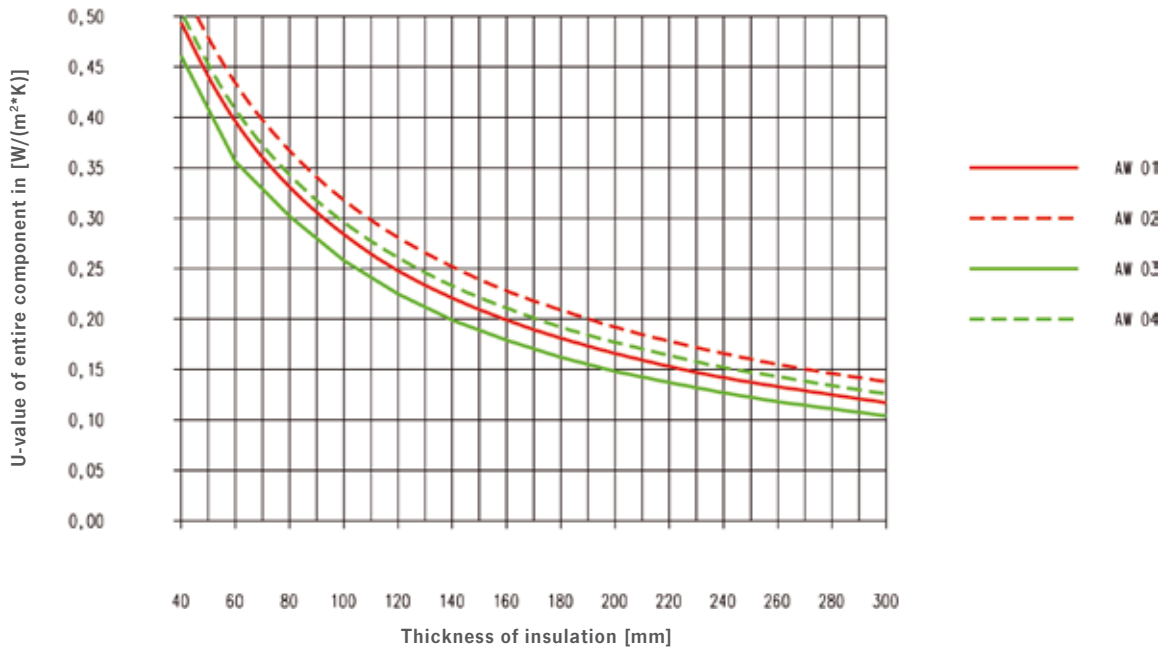

Fig. 7 – Graphic analysis of table 2

2.3 HEAT INSULATION IN SUMMER

Modern architecture often includes a large number of glazed surfaces. While these surfaces allow solar heat gains in winter, they create a more critical starting level in summer. When considering heat insulation in summer, it should normally be made sure that the maximum medium felt temperature inside rooms should not be exceeded, even without the use of air-conditioning. Buildings that need air-conditioning because of their specific usages should keep the cooling load at the lowest possible levels. Excess heating during summer is considered avoided if the felt temperature in any given room during the hot period does not exceed the defined temperature limits. [7.7]

Heat insulation in summer requires sound planning and an integrated approach to the following 3 aspects:

- loads
- ventilation
- type of construction

The term “loads” in inhabited rooms means the permeation of solar energy through windows. The most effective and cost-saving protection against overheating is sun protection applied outside of the building.

The proportion of heat transmission through opaque construction components, however, can be neglected in comparison.

Any planning effort should aim at creating an interior climate with as little a difference to the outside climate as possible, using natural ventilation through windows. Cooling provided by technical facilities with high energy consumption is not in line with sustainable planning for residential buildings.

HEAT INSULATION

Figure 8 shows the effectiveness of window ventilation depending on the position of the casements. A heat recovery ventilation system cannot make any significant

contribution here, because the air flow might well provide hygienic air change, but is not sufficient for transporting the excess amount of heat energy out of the building.

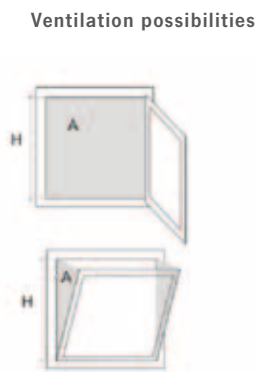

$$\dot{V} = C_{ref} \cdot A \cdot \sqrt{H} \cdot \sqrt{\Delta T}$$

$$C_{ref} = 100 \frac{m^{0.5}}{h \cdot K^{0.5}}$$

Volume flow in m³/h

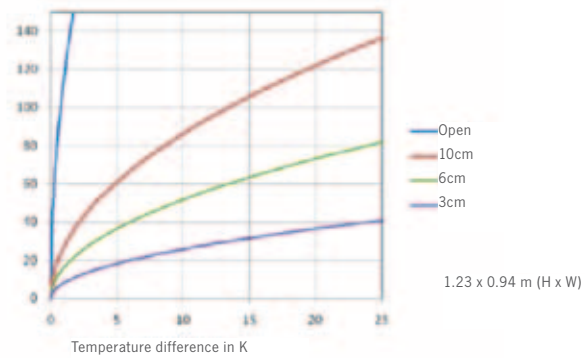

Fig. 8 – Relation of window casement position to the air change rate [7.8]

The increasing heat insulation thicknesses in residential building as a consequence of better heat protection in winter have led to the situation that the phase shift of the outer construction part is large enough – independent of whether “heavy” or “light” components are used. Simply put: what is good in winter is also useful in summer.

Solar heat energy that penetrates a building despite solar protection should be absorbed by surfaces enclosing a room to the greatest possible extent, without creating an unpleasant climate inside the room. The KLH solid wood wall can be used for heat storage, similar to a brick wall.

**In order to activate the masses in the building, the following conditions must be fulfilled:**

- Heat-storing construction material needs to be in direct contact with the ambient air (no facing formwork)
- Good heat insulation on the outside (is usually fulfilled)
- No covering of installations, carpets, cabinets (would have the same effect as facing formwork)
- The construction component participating in storing heat must be sufficiently thick

Planners should ensure that heat saved inside during daytime will be discharged at night – a principle that resembles a discharging battery.

Depending on air change rate, wind and temperature spread ( $\Delta T$  from inside to outside), ventilation at night only manages to discharge a limited amount of heat. Therefore, steel-concrete constructions will inevitably lead to overheating (“tiled stove effect”), unless expensive energy is used to cool it down.

## DURABILITY

KLH solid wood constructions therefore provide an optimal balance between heat saving during daytime and energy discharge at night. The most effective measure against overheating in summer is transparent solar protection, which retains up to 90% of the solar energy and still allows enough light into the rooms. The remaining

10% that reaches the room is saved in the KLH solid wood panels during the daytime. Due to natural ventilation at night, the energy storing KLH solid wood panel will automatically discharge energy during cooler night times. The risk of any insidious overheating in summer can be minimised this way.

### 03 DURABILITY

#### 3.1 INTENDED PURPOSE OF THE KLH SOLID WOOD PANEL

KLH solid wood panels are intended as load-bearing or non-load-bearing construction elements in timber frame constructions. They may be exposed to static, quasi-static and short-time dynamic loads (such as earthquake loads). They are intended to be used in the usage classes 1 and 2 according to EN 1995-1-1. [7.9]

Construction components directly exposed to weathering must be faced with effective weather protection.

Usage class	Ambient climate		Wood moisture of most conifers	Bearing structure or type of building
	Temperature	Relative humidity <sup>a</sup>		
1	20°C	≤ 65%	≤ 12%	Inside rooms of residential buildings, schools and administrative buildings
2	20°C	≤ 85%	≤ 20%	Inside rooms of commercial buildings such as warehouses, riding arenas and industrial halls as well as roofed-over outdoor constructions, with construction components that are not exposed to direct weathering (30° rainfall angle)
3	-	> 85%	> 20%	Outdoor constructions with constructional wood protection

<sup>a</sup> The relative humidity in the usage classes 1 and 2 may exceed the stated values for a maximum of a few weeks per year.

Fig. 9 – The allocation of bearing structures to usage classes according to EN 1995-1-1

The requirements are based on the assumption of a planned service life of KLH solid wood panels of 50 years. Information on the service life cannot be construed as any form of guarantee granted by the manufacturer. It is

merely given to facilitate the selection of the right product in the context of the expected, economically appropriate service life of a building. [7.10]

---

## DURABILITY

---

### 3.2 CONSTRUCTIONAL WOOD PROTECTION – CHEMICAL WOOD PROTECTION

Depending on the installation setting, wood may be exposed to wood-corroding organisms to various degrees. By using the hazard classifications in the standards, the type and scope of any required chemical wood protection measure can be evaluated. Installed wood with a hazard classification of 0 does not need any chemical wood protection.

Prior to using any chemical wood protection measures it must be verified as to what extent the wood can be protected by way of precautionary constructional measures, for example, by keeping it permanently dry (maximum humidity of 70%, maximum wood moisture of up to 20%).

Special attention has to be paid to contact areas of KLH solid wood elements with cold surfaces, such as foundations and basement ceilings. Critical climatic areas in the bearing area and possible formations of condensate

may cause long-term damage to wood constructions and should therefore be avoided. Constructional measures such as the installation of resistant larch sleepers or a technically correct base design lift the plywood panel out of the critical area. [7.7]

Only natural, unprocessed and untreated wood is used for the production of KLH solid wood panels. The individual layers are technically dried prior to gluing. On dispatch, KLH solid wood panels have wood moisture of 12% ± 2%. Installations according to the approved usage classes 1 and 2 do not usually require any chemical wood protection. Any treatment of the wood should be performed after cutting the panels to size. Due to the large number of wood protection products and their various mechanisms, the relevant wood protection product has to be selected only after verifying that it is suitable for the planned application, whether treatment on site or in the factory is reasonable and feasible.

### 3.3 PROTECTION FROM TERMITE ATTACKS

Termites may also attack dry timber. They live on everything that contains cellulose, including leaves and timber, or even paper.

There are two types of termites – earth termites and drywood termites. While the first type needs contact with the soil in order to form colonies and to maintain them, drywood termites, however, use wood as a place to live and as part of their food chain.

In general, wood can be preventively protected by way of constructional measures or chemical protection. For

environmental considerations, the constructional solution should be given priority, for example by placing KLH solid wood walls on reinforced concrete bases that avoid direct contact with the ground. A distance of only a few centimetres will already provide sufficient and effective protection.

If chemical preservation is wanted and/or required, it may be applied on all sides and narrow surfaces after cutting the panels to size.

## 04 PROTECTION AGAINST MOISTURE

### 4.1 FUNDAMENTAL ASPECTS

Wood as a construction material is not only able to transport moisture by way of diffusion, but also by way of sorption and capillary lines. In this respect, wood is incredibly effective, even if these research results of the last 20 years are not always noted by the wider public.

**We distinguish between 3 mechanisms that are responsible for the transport of moisture in wood**

- Vapour diffusion (vapour/pressure difference)
- Sorbate line (relative humidity)
- Capillary line (surface tension)

These are unsteady processes. Nevertheless, condensation water calculations on the basis of the Glaser method are still made, although this procedure only takes into account the diffusion in mineral construction materials, and is therefore far too narrow for wood. [7.11]

The KLH solid wood panel has a similar effect as a moisture-variable vapour retarder. In winter with low humidity, the ability for wood to transport moisture is reduced. It increases as soon as the inside air humidity has adjusted to the summer climate. Wood as a natural construction material always behaves in tune with nature – through its entire service life. If the tried-and-tested “more airtight inside than outside” construction principle is taken into account, the exterior wall is made safer in terms of building physics if a KLH solid wood panel is used.

Another characteristic of wood is that it swells and shrinks in relation to moisture. Wood is an anisotropic material with hygroscopic properties. Therefore, swelling and shrinking will vary, depending on the direction of the fibres.

**For sawn timber we distinguish the 3 main cutting directions as follows**

- Longitudinal (~0.01% change of shape per % change of moisture)
- Radial (~0.16% change of shape per % change of moisture)
- Tangential (~0.33% change of shape per % change of moisture)

Due to the crosswise arrangement of the layers and the high-quality gluing during the production of the KLH solid wood panels, these values are significantly reduced. On the plane of the panel, only a minor longitudinal shrinkage can be observed. As regards the thickness of the panel, a mean value between radial and tangential will apply.

- On the panel plane ~0.01% change of shape per % change of moisture
- At a right angle to the panel direction ~0.20% change of shape per % change of moisture (see “Technical Key Figures“)



PROTECTION AGAINST MOISTURE

4.2 DAMP ROOMS

In principle, floors and floorings of stone and ceramics are not watertight. The joint is the weak element. Although the KLH solid wood panel maintains its stable shape due to its crosswise gluing, it would be disastrous to lay tiles or comparable floorings directly onto the surface of the wooden panel. In order to avoid any excessive tension and bending stresses due to a change in shape, the KLH solid wood panel should be installed together with plasterboards. These low swell and low shrink boards

balance out movements between the KLH panel and the used surface.

Fig. 10 shows moisture-induced length changes of different, commonly used construction panels. It is quite clearly visible how different the swelling and shrinking behaviour of plasterboards is compared to panels with a wood content.

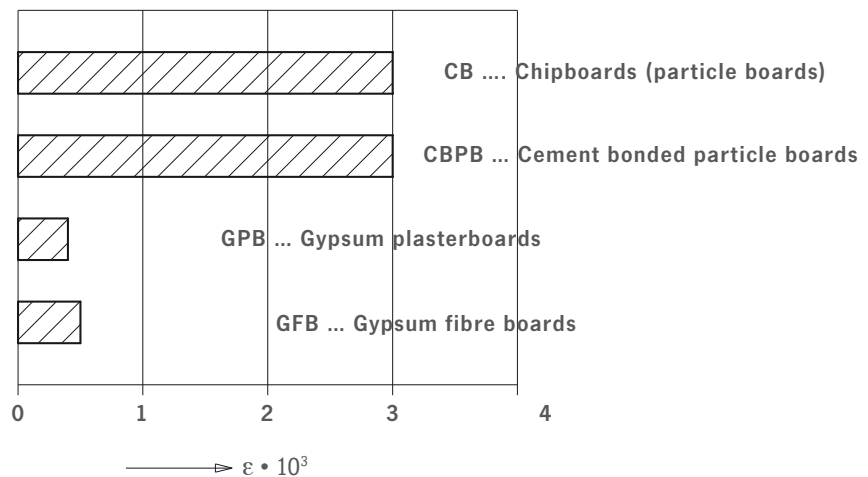
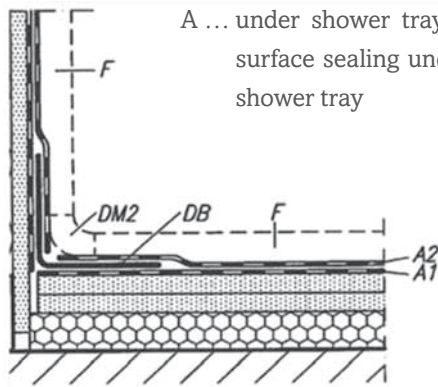

Fig. 10 – Different swelling and shrinking behaviour of common panel materials in relation to each other [7.12]

In corner areas of walls and floors material movements are unavoidable (impact sound insulation). This problem can only be solved by means of elastic, permanently flexible connections. Elastic sealing joints are also necessary for impact sound insulation towards side walls. At inaccessible points (shower trays, bathtubs) or in areas with strong splash water exposure (shower), the sealing should be made according to the following figure 11 (sealing at walls and floors). In the rest of the bathroom, construction according to figure 12 should be sufficient (sealing only on floors raised to the surrounding walls). At the rising wall planking with gypsum plasterboards is sufficient (damp room panels, compare fig. 11 and 12).

The floor area usually features two-layer gypsum fibre boards. Using construction products that have been approved for the floor area as a reference is recommended. In wooden constructions it is also recommended that one additional, simple sealing layer below the floor structure be applied, directly on the KLH ceiling panel. The sealing layer should be designed with flooring all around raised to the walls, and have a drainage option available in the installation duct. In case of a pipe burst potential water damage can be detected early on, and any further damage to the building can be prevented.

PROTECTION AGAINST MOISTURE



A ... under shower trays with continuous surface sealing under and behind the shower tray

- S1/S2 ... 1<sup>st</sup> and 2<sup>nd</sup> sealing
- ST ..... sealing tape
- SC ..... sealing compound
- TF ..... tile flooring, if already applied on the wall

Fig. 11 – Corner formation and sealing in the splash water area.  
The sealing “F” must be continued behind the tiles. [7.12]

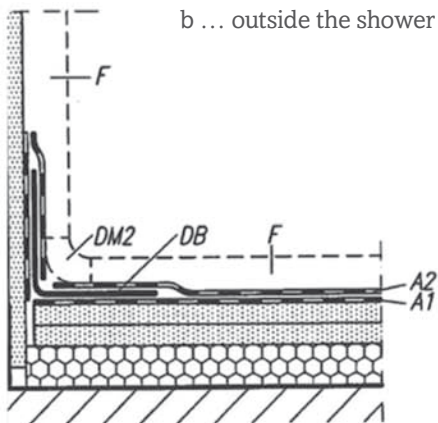

b ... outside the shower tray in the rest of the bathroom

Fig. 12 – The sealing in areas not exposed to splash water. No additional sealing to the wall is necessary. [7.12]

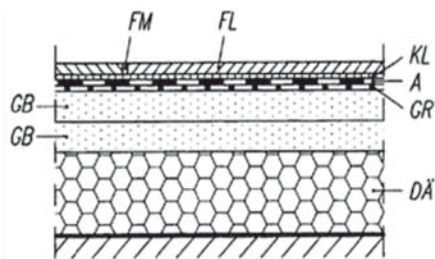

- TL ... tile
- JM ... joint mortar
- AD ... adhesive, hydraulically hardened thin-bed mortar
- C ..... closing off of the entire area, modified plastic dispersion
- PR ... priming, if required by the adhesive manufacturer
- PB ... plasterboard, drywall or gypsum fibre board – observe rating
- IL..... insulation layer

Fig. 13 – Floor structure and sealing in the area [7.12]

PROTECTION AGAINST MOISTURE

Below are some examples to illustrate the splash water area according to the “Information sheet for bathrooms and wet rooms in timber construction and drywall construction” by Info-Dienst Holz. On areas marked in grey, sealing according to fig. 11 to 13 has to be used.

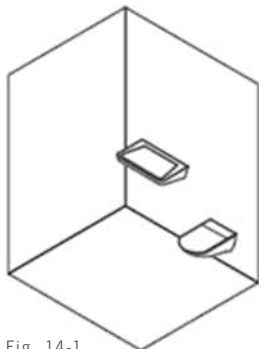

Fig. 14-1  
Guest toilet

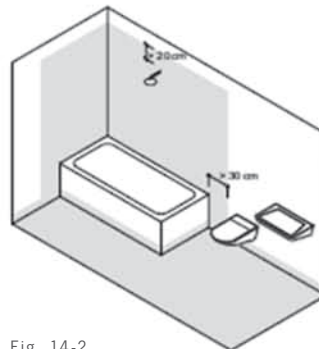

Fig. 14-2  
Bathroom with bathtub as shower

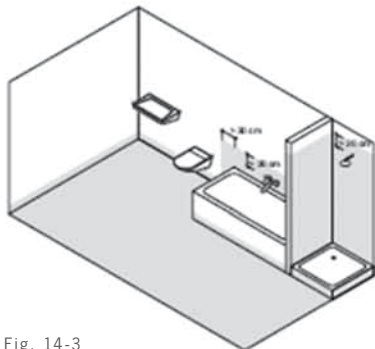

Fig. 14-3  
Bathroom with tub without shower function and shower

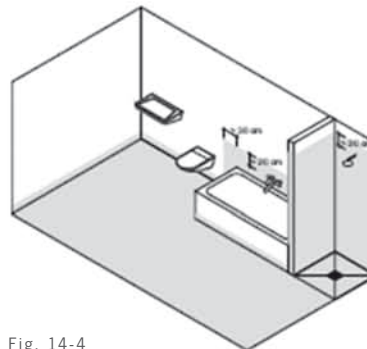

Fig. 14-4  
Bathroom with tub without shower function and floor drain in shower area used as planned

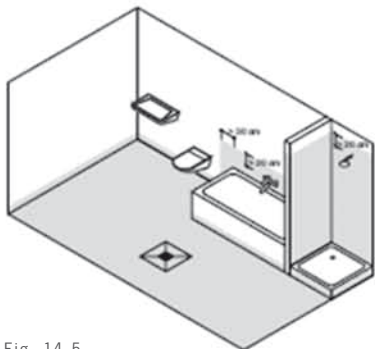



Fig. 14-5  
Bathroom with tub without shower function and floor drain not used as planned

no or very little exposure to splash water, exposure class 0 

moderate exposure to splash water (splash water area), exposure classes A01, A02 

Fig. 14 – Splash water exposed areas in bathroom

---

## SOUND INSULATION

---

### 4.3 MOULD FORMATION

Mould and its spores are a natural part of our environment and are also present in the interior. They grow on a large number of materials and across a wide range of temperatures. Moisture – especially on material surfaces – plays an essential role.

Such moisture is most often the result of constructional defects (e.g. thermal bridges or open joints in components) and damage events (water pipe burst, insufficient connection joints in bathrooms) as well as insufficient ventilation and/or hygiene.

Mould does not destroy the building fabric – it needs it as carrier material for its own growth, but also uses its substances as a possible food source. As mentioned, it can grow across a wide temperature range. Therefore,

not only the inside surface temperature is important, but also the predominant level of relative humidity. Scientists have set a surface temperature limit of 12.5°C for mould development. Under normal conditions of 20°C and 50% relative humidity in interior rooms, the 12.5° isothermal lines have a humidity of 85%. These 85% of relative humidity are usually not sufficient for the development of moulds – independent of the construction material.

Due to its hygroscopic properties and its content materials, wood has a higher moisture tolerance than mineral construction materials. Sandwich-type wall structures and the possibility of moisture storage provided by KLH solid wood panels create a significant safety potential and therefore the increased hygro-thermal application tolerance of structures with KLH solid wood panels.

## 05 SOUND INSULATION

### 5.1 CURRENT DEVELOPMENT IN THE FIELD OF STANDARDISATION

In the process of harmonising standards within the EU, measurement and calculation procedures for sound parameters of construction components and buildings have been standardised.

The intention is to break down buildings into their individual components (such as walls, ceilings, windows ...)

and to make an exact determination of their sound insulation properties in a laboratory. This results in test certificates that only exhibit whole figures, free from influences by secondary sound paths (flanking transmission).

SOUND INSULATION

In the past, test certificates showed  $R'$  and  $L'$  values. New certificates do not show these values anymore. The slight difference between “old” and “new” is in the “index line”. This difference states whether a value has been determined with or without flanking transmission. Fig. 16 shows an outlay of the possible spreading paths of airborne and footfall sound.

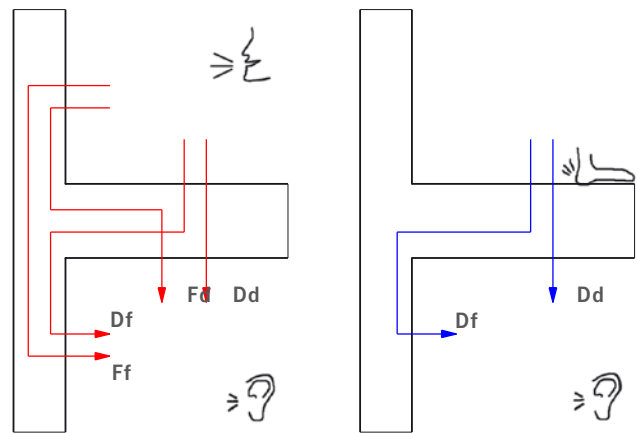

Fig. 16 – Airborne sound and impact sound transmission paths between adjacent rooms [7.13]

In a second step the coupling situation between a separating construction component and its adjacent side components is analysed and assessed by way of calculations, as far as possible. The separate analysis of construction components and secondary sound paths now also allows conclusions on possible measures of improvement, if necessary. If, for example, the sound insulation across the flanks is too weak, then it does not make sense to improve the separating component itself. One tried-and-tested method of improving the flank situation is the installation of elastic layers between KLH wall and ceiling components. Fig. 17 shows a combination of products of various manufacturers. Depending on the selected floor and wall structures, the bearings may either be installed below or above the ceiling, in order to achieve the best possible absorption of the joint spot. In the course of planning, a decision has to be made whether the nodal points are made with or without elastic bearings.



Fig. 17 – Bearing by Getzner (red, bottom) and Trelleborg (black, top) as possible improvement of the flank [7.7]

---

## SOUND INSULATION

---

In a third step the energies of both individual components are added. The result is the expected sound insulation in the building. Impact sound at the construction site  $L'_n$  results from the energetic addition of „D<sub>d</sub>“ and „D<sub>f</sub>“ for example (compare fig. 16).

$$L'_n = 10 \log \left( 10^{(L_n/10)} + 10^{(L_{n,Df}/10)} \right) [\text{dB}]$$

$L'_n$  impact sound pressure level including secondary paths

$L_n$  impact sound pressure level of the component measured in a laboratory

$L_{n,Df}$  impact sound pressure level across the flank

Previously – especially in the German-speaking area – sound insulation properties of construction components were often determined on the basis of sample buildings. The planned wall and ceiling structures were set up on a test rig together with the usual technical secondary sound paths, before sound measurements were performed. This resulted in “mixed results” of direct sound transmission (construction component) and the secondary paths present at the test rig. The resulting figures were usable for planners insofar as the actual building situation was comparable with the laboratory set-up. The separated analysis of component and flank can therefore be regarded as an additional tool for planners, in order to reach the required sound insulation values with light-weight components as well.

### 5.2 SOUND INSULATION IN RELATION TO KLH SOLID WOOD PANELS

Ambient noise and increasing stress in the working world make quiet and relaxing homes more important than ever before. The highest sound insulation demands apply to components separating individual homes.

In order to meet these high requirements, a second layer is usually introduced according to the state of technology. Even classic solid construction must resort to this solution in order to reach the required values, because any increase of masses would no longer yield the desired effect. A double partition with KLH solid wood panels is therefore equally efficient as two-layer solutions from classic solid construction. The structures have comparable component thicknesses, but solid wood constructions are five times lighter (weight reduction by a factor of 5).

The basic prerequisite is the careful planning of details, knowing the principles of sound insulation and correct technical implementation of the sound insulation concept at the construction site. Another option for designing

effective construction components is the combination of KLH solid wood panels and elements of dry construction or light-weight construction.

Despite the lack of mass, the same or even better values are achieved through inner material damping and softness of components (for example, by way of facing formwork) than in solid mineral construction.

For more than a decade, KLH Massivholz GmbH has been carrying out research and development together with institutes that are acknowledged throughout Europe in order to continuously improve sound insulation of KLH constructions. For many years the company has had its own wall and ceiling test rigs and the required equipment to offer clients the appropriate solutions individually and quickly.

## SOUND INSULATION

Basically, acoustics are divided into 2 main areas

- Room acoustics (audibility in a room)
- Building acoustics (sound insulation between individual rooms)

Sound insulation from one room to another plays a very important role. Planning mistakes regarding room acoustics may be inconvenient, but such problems can usually be remedied at relatively low costs.

If, however, planning mistakes are made in the field of building acoustics (transmission of airborne and impact sound), improvement measures very often entail considerable costs.



Fig. 18 – Repair work at a two-layer aerated concrete masonry wall with a double-sided saw blade on a 5 metre long blade [7.14]



Sound is transmitted vertically, horizontally and also diagonally. Sound penetrating a construction component (solid object) is called structure-borne sound. Its complexity is very different from airborne sound that plays a role in room acoustics. Ultimately, it is always a question of the transmission of structure-borne sound, but in discussing sound insulation in buildings a difference is always made between airborne and impact sound. The difference is in the excitation of construction components.



Fig. 19 – Dome loudspeaker as it is used in determining airborne sound insulation [7.14]

**SOUND INSULATION**

**Both airborne sound transmission and impact sound levels in the entrance room are decisively influenced by**

- Weight of the construction component per m<sup>2</sup>
- Internal damping of the component
- Leaf distance in case of multi-leaf structures
- Dynamic rigidity of the separation layer in case of multi-leaf structures (e.g. impact sound insulation between screed and KLH solid wood panel)
- Flexibility as defined in building acoustics
- Minimisation of sound transmission through contact surfaces and fixing elements

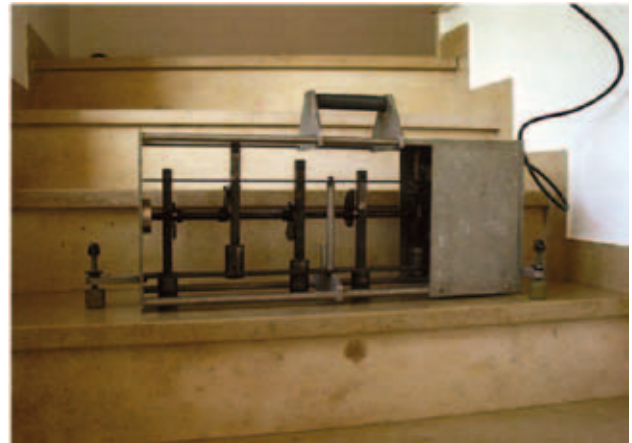

Fig. 20 – Standard impact machine as it is used in determining impact sound levels [7.14]

Modern calculation programmes and a large number of construction component measurements facilitate the determination of building acoustic properties of individual components. In order to comply with sound protection requirements for a particular construction it is, however, not sufficient to only determine the properties of the separating components. The influence of secondary sound paths also has to be taken into account. The more

efficient the main separating component is, the stronger the influence of secondary sound paths will be. Depending on the type of stimulus, the sound energy will follow different paths. Similar to electric current, sound also always follows the path of least resistance. In this context it is important to consider improvements to the separating component as early as during the planning stage, but it is equally important to take flank paths into account as well.

**Planners may use the 3 following tools**

- Constructional separation of components (e.g. continuous ceilings have to be avoided)
- Partial decoupling by way of soft, resilient sandwich layers
- Protection barriers (facing formwork makes it harder for sound energy to enter or exit)

The third measure is also the most effective one. It not only improves sound insulation, but also increases fire protection and provides a neutral surface.



## 06 FIRE PROTECTION

### 6.1 FLAMMABILITY OF KLH SOLID WOOD PANELS

The reaction of KLH solid wood panels to fire is defined in the European Technical Approval ETA-06/0138 with D-s2, d0. It therefore corresponds to the combustibility of solid wood.

#### REACTION TO FIRE

Class	Property
A1	non-combustible
A2	practically non-combustible
B, C, D	increasing combustibility
E	minimum requirement as construction material
F	not permitted as construction material

#### SMOKE FORMATION

Code	Property
s 1	little formation of smoke
s 2	medium formation of smoke
s 3	strong formation of smoke

#### FLAMING DROPLETS OR DEBRIS

Code	Property
d 0	no flaming droplets or debris
d 1	short-time flaming droplets or debris
d 2	continued flaming droplets or debris

By using fire-proof coatings, the reaction of KLH solid wood panels to fire can be improved from D-s2, d0 to C-s2, d0 or even B-s1, d0.

It is absolutely necessary to distinguish between coatings applied in interior areas or in outdoor areas. Coatings in outdoor areas may require additional UV-resistance.

### 6.2 FIRE RESISTANCE – CRITERIA “R”, “E” AND “I”

#### Proof of load-bearing capacity – criterion “R”

The proof of the load-bearing capacity must be established for each individual construction component in the form of a static calculation. The European Technical Approval ETA-06/0138 clearly defines the mass burning rates for KLH solid wood panels. On this basis the proof of the load-bearing capacity in case of a fire is provided according to Eurocode 5.

---

## FIRE PROTECTION

---

If the surface of KLH solid wood panels is protected against fire by planking with, for example, plasterboard fire protection slabs in the beginning, the failure times of the planking may be considered in determining the overall rating. By using the multi-layered KLH solid wood panels, components can be designed with higher fire resistance, and proof can be provided for R90 or R120, for example.

5-layer KLH solid wood panels mostly reach R60 without additional measures or even R90 if the thickness of the panel is sufficient. This way, even visible constructions can be realised with high levels of fire resistance. Another increase can be achieved by either increasing the thickness of the panels and/or the number of layers and/or by way of appropriate planking.

In order to increase economic efficiency or to maintain the slim design of components, wall components are often realised with 3-layer KLH solid wood panels (max. R30) plus additional planking.

It has to be pointed out that load-bearing interior walls will most often be exposed to combustion on both sides. Special attention should also be paid to pillars between windows and doors in exterior walls.

### **Proof of integrity – criterion “E”**

The criterion of integrity is regarded fulfilled if two completely intact panel layers as well as a 5 mm thick residual lamella on the side exposed to the fire are left after a fire. This means that a 3-layer residual panel with two fully intact glue joints has to survive the fire.

### **Proof of heat insulation – criterion “I”**

The criterion of heat insulation is of minor importance for constructions made of KLH solid wood panels, because it is already regarded fulfilled with a residual panel thickness of a few centimetres.

---

## BIBLIOGRAPHY

---

### 07 BIBLIOGRAPHY

- |   |   |
|---|---|
| <p>[7.1] <a href="http://www.luftdicht.de/luftdicht_in_enev2009.htm">http://www.luftdicht.de/luftdicht_in_enev2009.htm</a></p> <p>[7.2] OIB- Richtlinie 6, April 2007, 7.2.1 f., Seite 7</p> <p>[7.3] IBO- österreichisches Institut für Baubiologie und-ökologie, Passivhaus Bauteilkatalog, Springer Wien New York, 2008]</p> <p>[7.4] 5. Grazer Holzbau-Fachtagung - 5. GraHFT'06 – Tagungsband Kapitel L:<br/>Forschung an der TU Graz – Bauphysikalische Aspekte für den Holz-Massivbau mit BSP<br/>DI Heinz Ferk, Leiter des Labors für Bauphysik im Bautechnikzentrum der TU Graz</p> <p>[7.5] ÖNORM EN 12524 Baustoffe und -produkte - Wärme- und feuchteschutztechnische Eigenschaften - Tabellierte Bemessungswerte, Ausgabedatum: 2000-09-01</p> <p>[7.6] ÖNORM B 3012, Holzarten - Kennwerte zu den Benennungen und Kurzzeichen der OENORM EN 13556, Ausgabedatum: 2003-12-01</p> <p>[7.7] BSPHandbuch – Kapitel F: Bauphysik – Hochbau – Leitdetails Holz-Massivbauweise in Brettsperrholz – Nachweise auf Basis des neuen europäischen Normenkonzepts Technische Universität Graz – holz.bau forschungs gmbh – Karlsruher Institut für Technologie – Technische Universität München – Eidgenössische Technische Hochschule Zürich</p> | <p>[7.8] Bednar T., Vortragsreihe Sommerlicher Wärmeschutz, MHC Linz, 2010</p> <p>[7.9] ÖNORM B 1995- 1- 1, 15.08.2010</p> <p>[7.10] ETA- 06/0138 der KLH Massivholz GmbH</p> <p>[7.11] Borsch- Laaks R., Holzbau die neue Quadriga 5/2003, "Jenseits von Glaser"</p> <p>[7.12] Informationsdienst Holz, Holzbau Handbuch, Reihe 3, Teil 2, Folge 1: "Naßbereich in Bädern"</p> <p>[7.13] Teibinger M., Dolezal F., Matzinger I., Deckenkonstruktionen für den Mehrgeschossigen Holzbau Schall- und Brandschutz, Detailkatalog, Band 20 der HFA- Schriftenreihe, 1. Auflage Mai 2009</p> <p>[7.14] H. Baumgartner, R. Kurz; Schadensfreies Bauen, Hrsg. G. Zimmermann, Fraunhofer IRB Verlag, 2003, Seite 126</p> |
|---|---|

---

NOTES

---

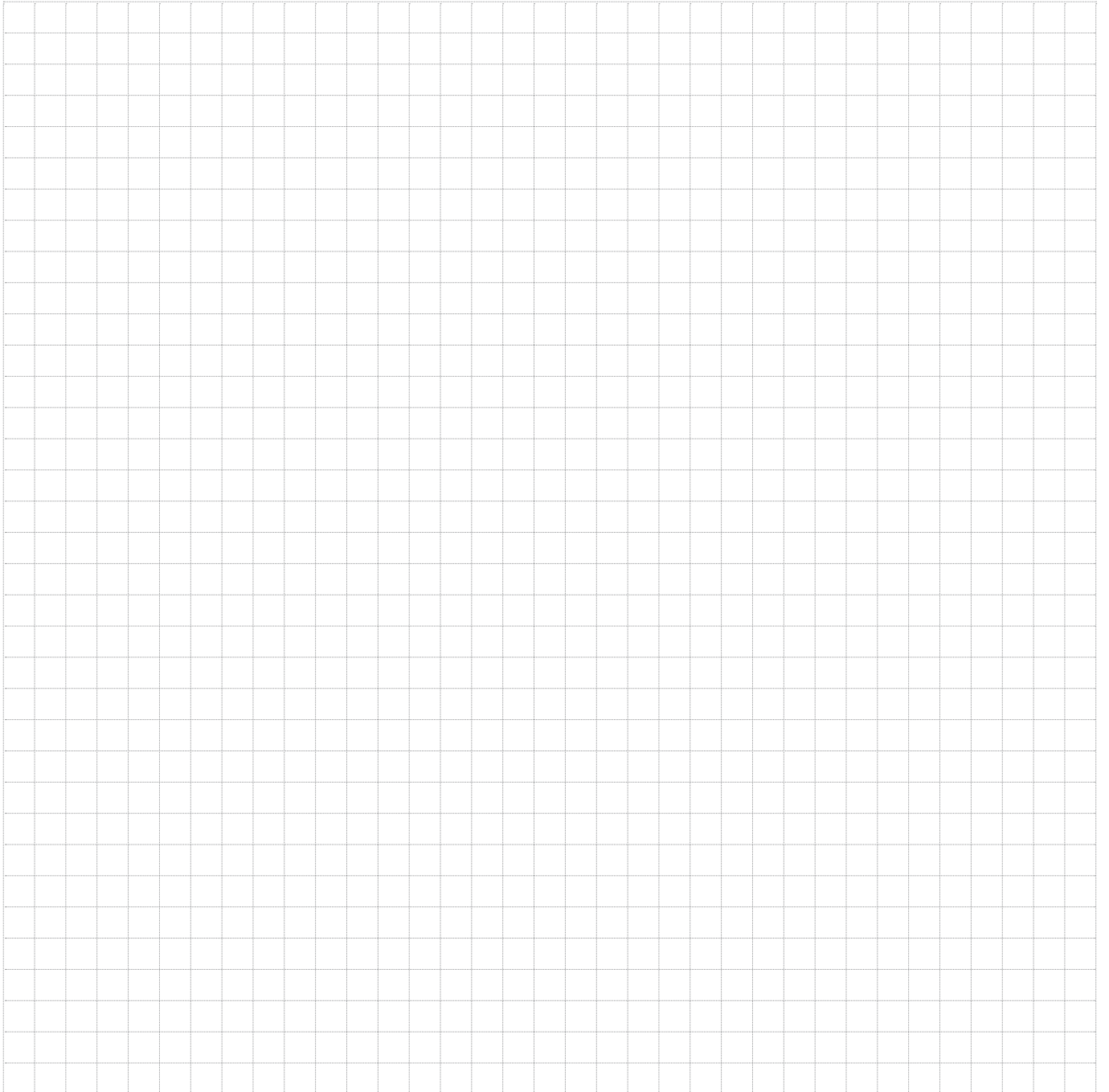

---

**NOTES**

---

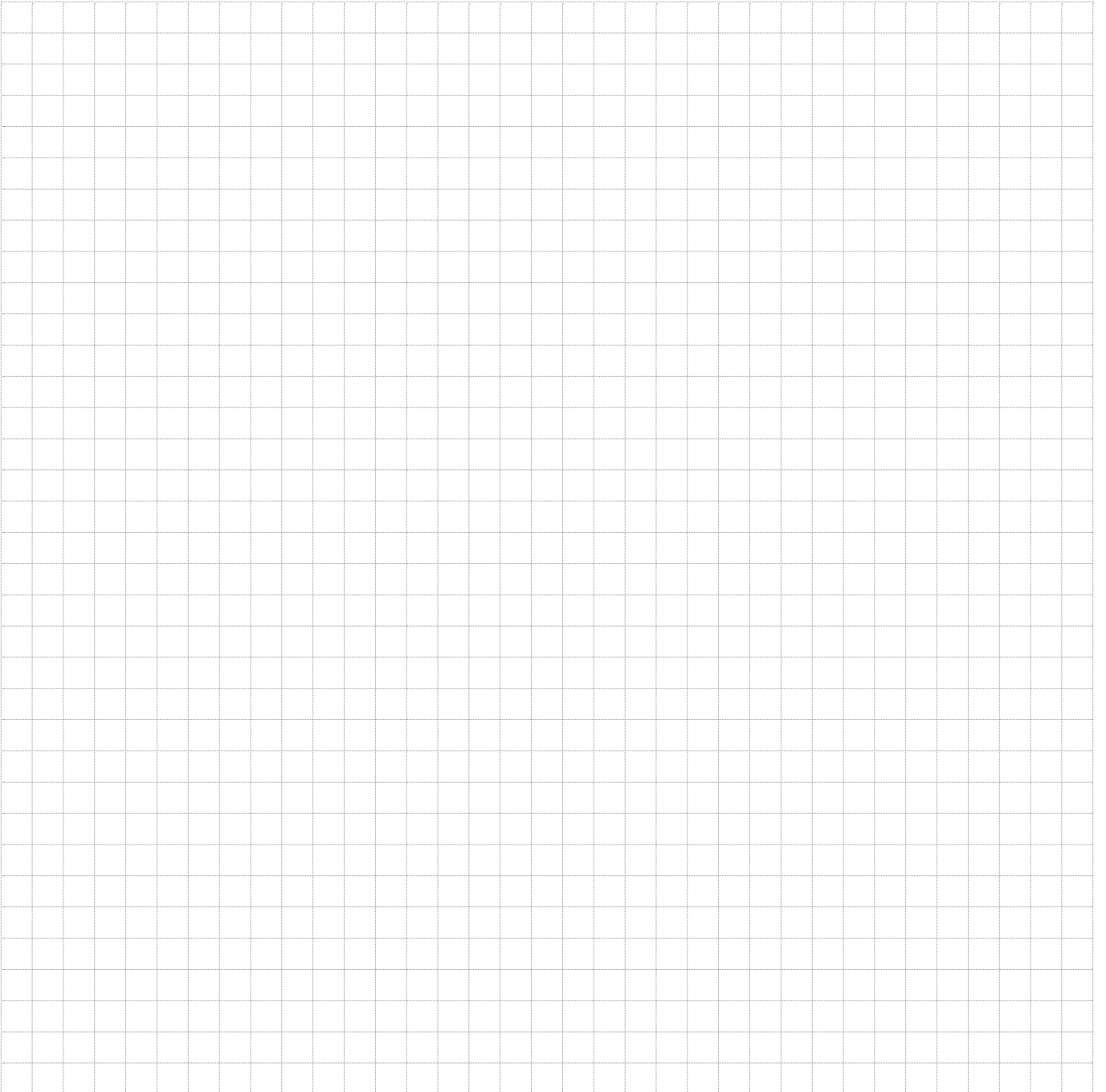

---

**NOTES**

---

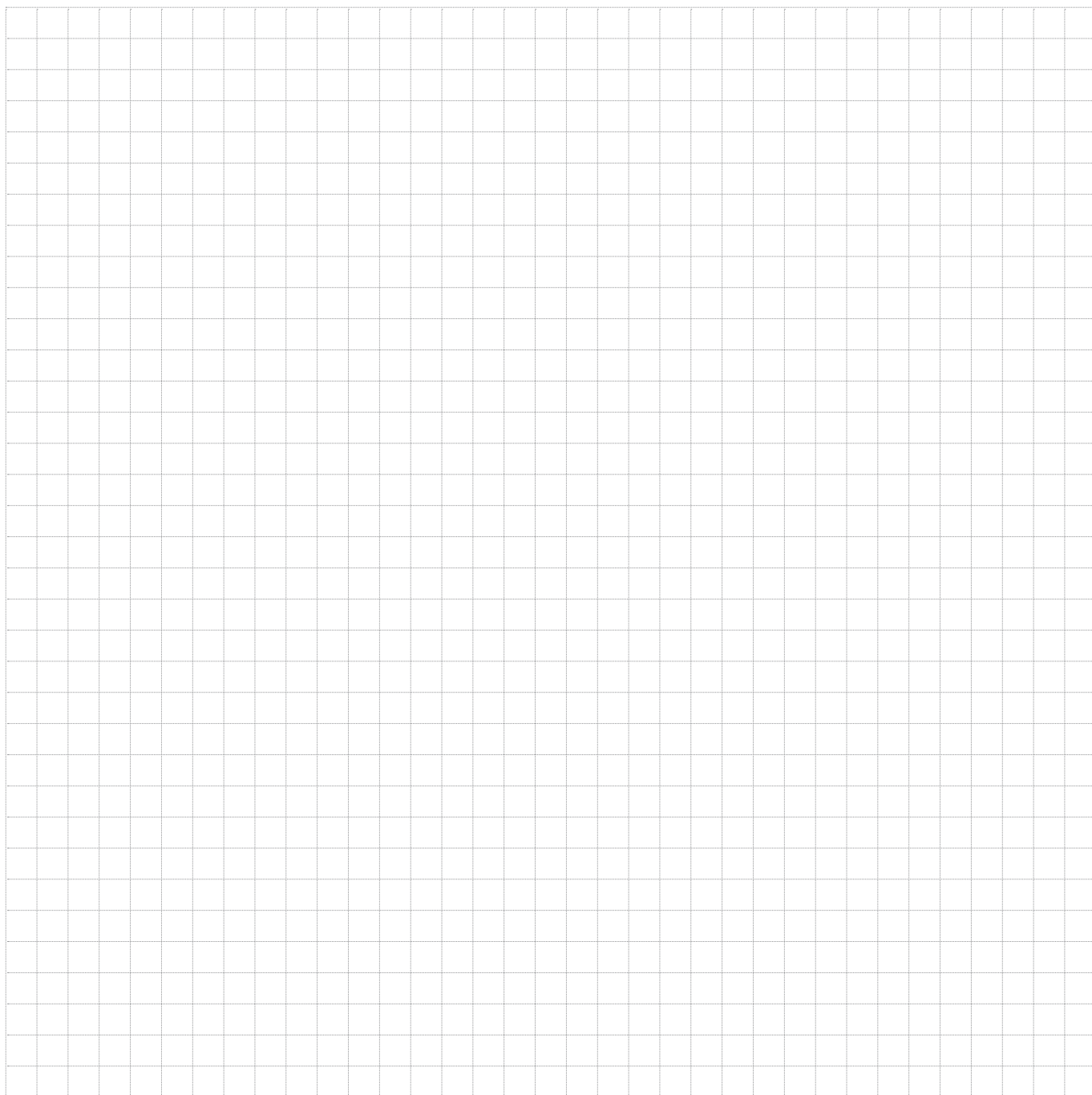





**KLH MASSIVHOLZ GMBH**

A-8842 Katsch a. d. Mur 202 | Tel +43 (0)3588 8835 0 | Fax +43 (0)3588 8835 20  
office@klh.at | www.klh.at



For love of nature



Printed on ecologically friendly paper